

IBMC 48V280A3

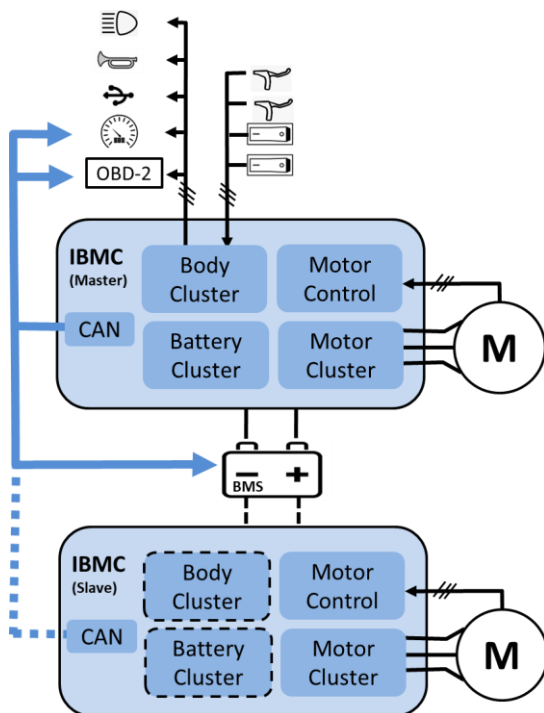

For more information please contact:
Mr. Stefan Dosch
Mobile: +49 173 5766902
E-mail: stefan.dosch@ideasandmotion.com

- Unique, 48V based system solution for light electric vehicles incl. E-mopeds, E-motorbike, E-vehicle (L3e-L6e)
- Control of multiple motor types incl. PMSM, TFM and BLDC.
- 48V, 115Arms(continuous)/280Arms (peak (10s)), 7kVA (continuous)/15kVA (peak) power
- FOC or DFVC with “Full Field Weakening”
- Up to 98% efficiency
- Easy motor adaptation and optimization with full motor mapping support (e.g. MTPA, MTPS)
- Master/slaves configuration for multiple motors
- 3 drive modes, quick customization available
- Protection, diagnostic and safety functions
- Communication with BMS for range estimation and battery supervision
- Onboard diagnostic function integrated (OBD-2)
- Integrated body controller with outputs for lights, horn etc. (24V,12V,5V) and inputs for switches, brake, sensors etc.
- IP67, 780g, dimensions(LxWxH): 152x142x44mm
- Product status: In production